



OZ Optics

www.ozoptics.com

219 Westbrook Rd, Ottawa, ON, Canada, K0A 1L0 Toll Free: 1-800-361-5415 Tel:(613) 831-0981 Fax:(613) 836-5089 E-mail: sales@ozoptics.com

REFLECTORS – FIBER OPTIC (FIXED OR VARIABLE)



Fiber optic reflectors are used to reflect the light emerging from a fiber back in the reverse direction. They are used to build fiber interferometers, or with fiber fused splitters to measure backreflection within fiber optic components. They can also be used to measure the sensitivity of sources to backreflection from other devices, by providing reference reflection levels. This is very useful for deriving backreflection specifications for transmitters.

Fiber optic reflectors consist of a fiber optic collimator and a mirror. The fiber output is first collimated, then it strikes the mirror and is reflected back into the collimator. The angle between the collimator and the mirror is adjusted using OZ Optics' patented tilt adjustment technique, until as much light as possible is reflected back into the fiber. Using this technique, reflectors with typical losses of only 0.6 dB can be constructed. A variable reflector is available that includes a blocking screw, to obtain variable reflection levels. This is achieved by partially blocking the collimated beam between the lens and the mirror.

Both connector receptacle style and pigtail style reflectors are available. Connector receptacle style reflectors come with a female connector receptacle to allow the fibers to be easily changed.

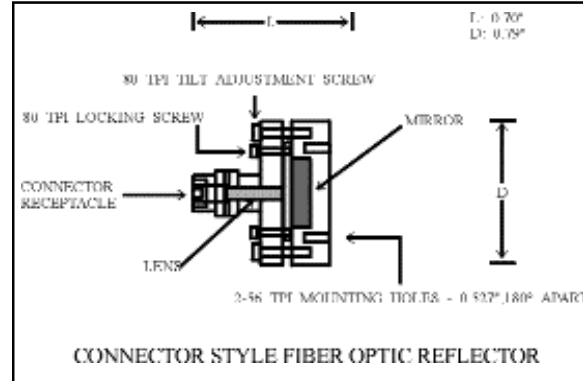

Pigtail style reflectors come with a fiber of your choice permanently attached to the collimating lens. This type of reflector is recommended for optimum coupling efficiency and stability. The other end of the fiber can be terminated with your choice of connector.

OZ Optics also sells fibers with coated ends. Gold coatings are used to provide excellent broadband reflection for infrared wavelengths. Other coating materials are available for other wavelengths. The ends can have either 100% reflecting, or partial reflecting/partial transmitting coatings. Contact OZ Optics for further information.

Reflectors are available for wavelengths from 400nm to 1600nm. Reflectors that operate at both 1300 and 1550nm are available, with only a slight difference in insertion losses at both wavelengths. Broadband reflectors using achromatic lenses to collimate light at different wavelengths are available. Partially reflecting mirrors are also available, to partly transmit the light. The transmitted light can be coupled into an output fiber as an option, thus forming an in-line reflector. Contact OZ Optics for further details. Laser diodes or lasers with long coherence lengths can cause etalon effects in fiber optic reflectors.

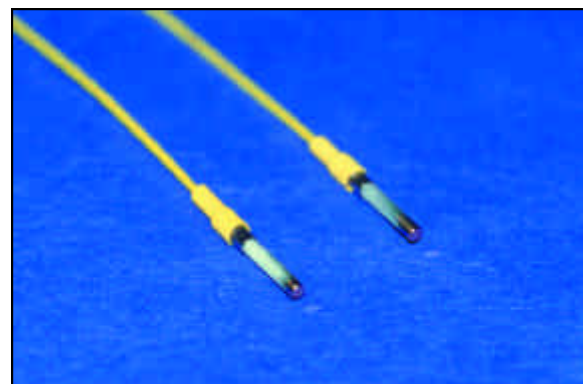
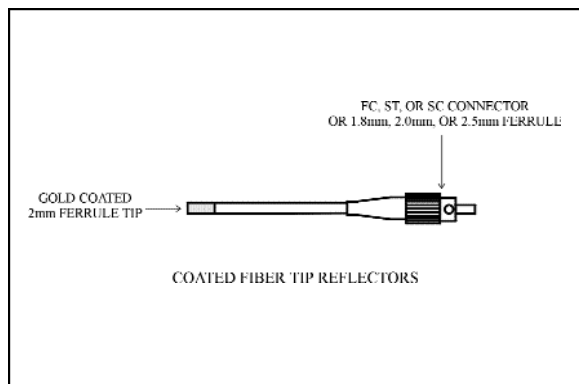

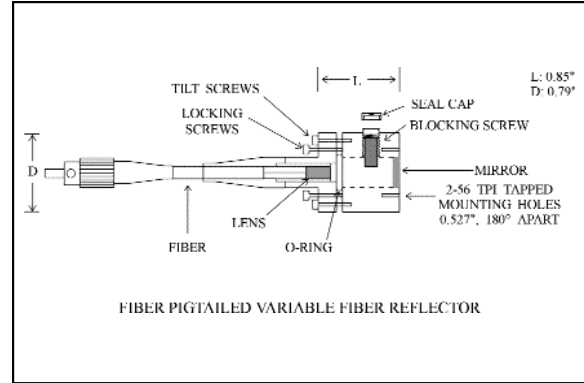
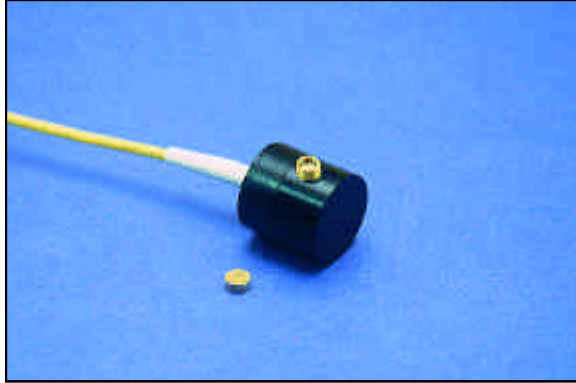

ORDERING INFORMATION:

<u>Part Number</u>	<u>Description</u>
FORF-1X-W-F	Connector receptacle style fiber optic total reflector.
FORF-XY-W-F-R	Connector receptacle style partial reflector with output fiber focuser.
FORF-11P-W-a/b-F-LB-X-JD-L	Pigtail style fiber optic total reflector.
FORF-21P-W-a/b-F-LB-R-XY-JD-L	Pigtail style partial reflector with output fiber focuser. Consult Factory for partial reflectors without output fiber.
FORF-31P-W-a/b-F-LB-X-JD-L	Gold tipped fiber total reflector.

Where: **W** is the operating wavelength in nm. (If the reflector is to work over a range of wavelengths, then give both the shortest and longest wavelength to be coupled into the fiber.);

X, Y are the connector receptacle types for connector style reflectors. For pigtail style reflectors, it refers to the male connector on the fiber ends (3 for NTT-FC, 3S for Super FC, 3A for angled FC, 8 for AT&T-ST, SC for SC connectors, etc.);

a/b are the fiber core and cladding diameters, respectively, in microns;

F is the type of fiber being used (S for singlemode, M for multimode, P for polarization maintaining fiber);

R is the percent reflectance for a partially reflecting mirror;

JD is the fiber jacket type (1 for uncabled fiber, 3.0 for 3 mm OD loose tube kevlar, 3A for 3mm OD armored cable, and 5A for 5mm armored cable);

L is the fiber length in meters.

LB is the desired backreflection level (25dB, 40dB, 50dB, or 60dB) from reflective surfaces other than the mirror.

Note: Add the term "-BL" to the end of the part number to add a blocking screw to achieve variable reflection.

Example: A customer requires a pigtail style fiber reflector for 1300nm, with a blocking screw for variable reflection. The fiber is 9/125 singlemode fiber, one meter long, cabled, and terminated with an angled FC connector. OZ Optics part number: **FORF-11P-1300-9/125-S-60-3A-3-1-BL**.

